



PAVERS | WALLS | OUTDOOR LIVING



# Why Choose Keystone?



## AMERICAN-MADE WORLD CLASS MANUFACTURING

Keystone is proud to be American-Owned and Made. We manufacture our products across the country at numerous manufacturing facilities.



## NETWORK OF DEALERS & AUTHORIZED CONTRACTORS

You can find our products throughout the country, with sales locations that service both contractors & dealers. We have a valued dealer network who are knowledgeable about our products and have our products on display. We take great pride in providing in-depth regional training programs for contractors to become Authorized Keystone Hardscapes Contractors. To connect with a dealer or authorized contractor in your area, please visit [keystonehardscapes.com](http://keystonehardscapes.com)



## EXPERIENCED PROFESSIONAL ADVICE

We are more than your supplier, we are your partner. We recognize the importance of sales support and inventory. We have a phenomenal team that's trained to be your resource. Our knowledgeable staff provides expertise from sales support and installation techniques, to delivery.

## APPLICATION KEY

### Pavers

- Pedestrian
- Light Vehicular
- Medium Vehicular
- Heavy Vehicular
- Permeable
- ADA Compliant

### Walls

- Retaining Walls
- Freestanding Walls
- Outdoor Living

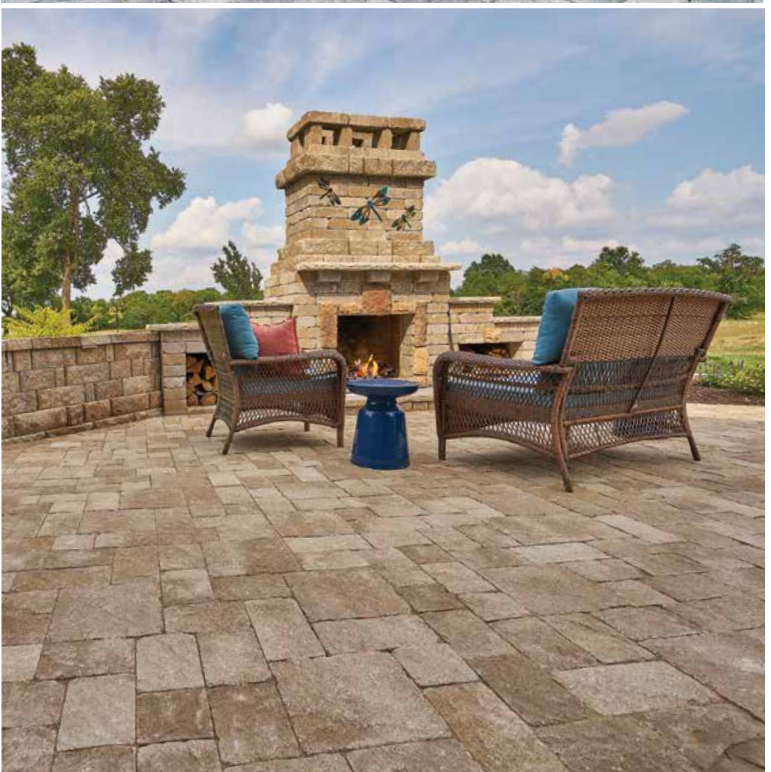
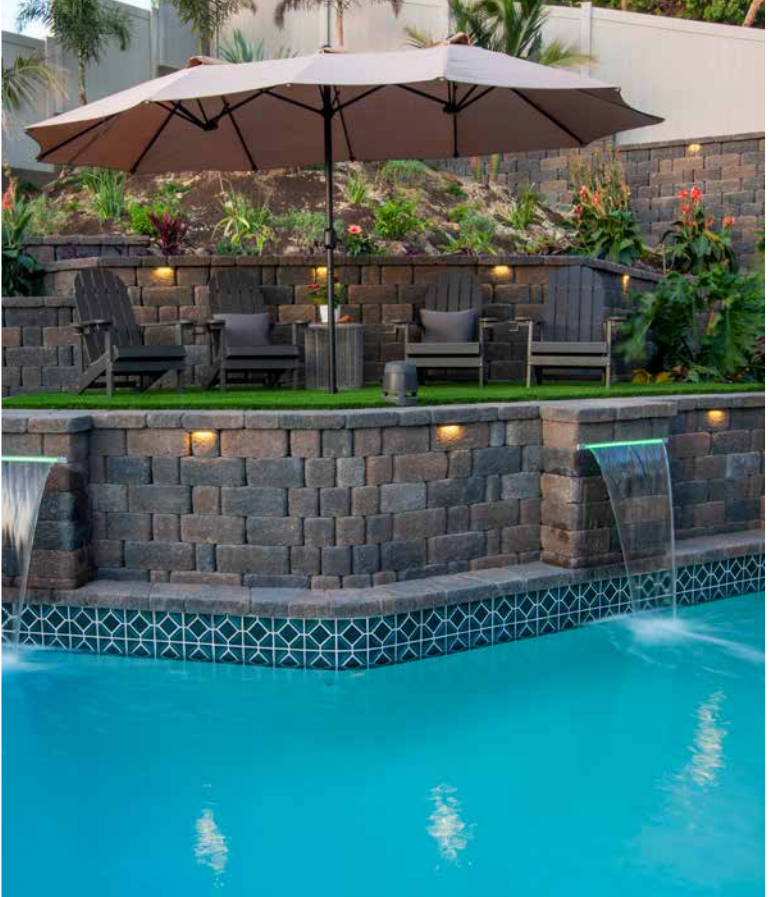
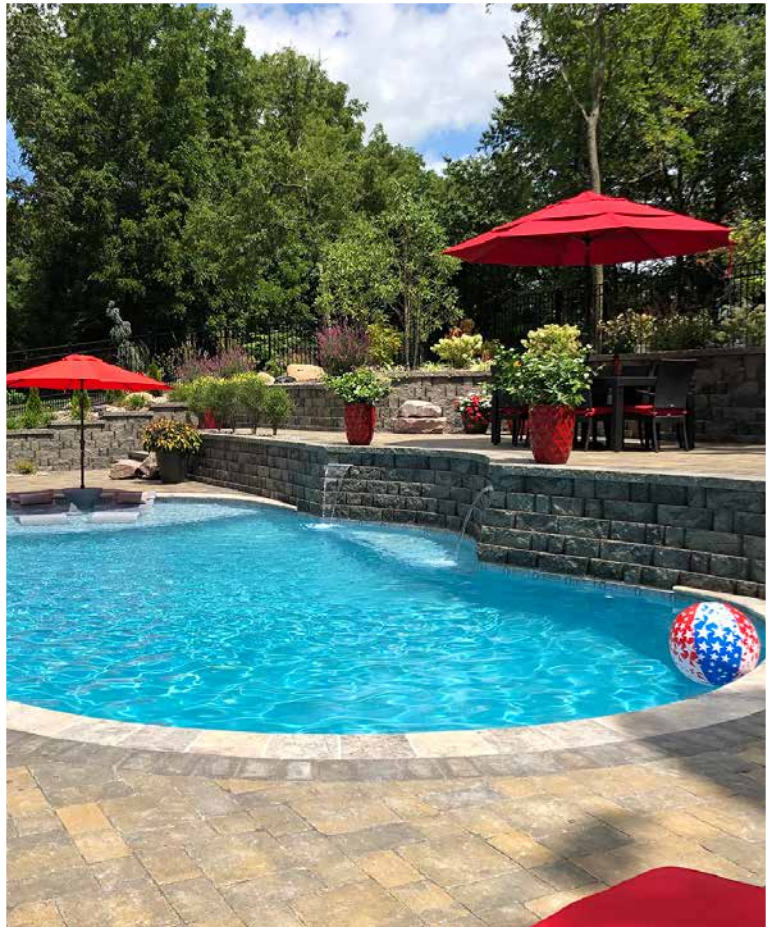

# Contents

## INSPIRATION

Why Choose Keystone®	2-3
Find Your Authorized Contractor	4-5

## PAVER COLLECTION

### Pavers

CityStone™ Demi & Supra	8-9
Panorama™ Demi & Supra	10-11
Venetian®	12-13
Venetian® - Tumbled	14-15
Venetian® Flag	16-17
Vintage Stone®	18-19
Vintage Stone® - Tumbled	20-21
Holland Stone	22-23
CityScape ADA Paver	24-25
CityStone™ 4x4	26-27

## WALL COLLECTION

### Structural Walls

Regal Stone Pro® - Medley	30-31
Regal Stone Pro® - RockFace	32-33
Regal Stone Pro® - Tri-Plane	34-35

### Landscape Walls

Harington® - 3-pc	36-37
Harington® - Medley	38-39
Harington® - Freestanding 3-pc	40-41
Rumbled Wall™	42-43
Stonegate® - Old World	44-45
Stonegate® - Contemporary	46-47
12 Inch Retaining Wall	48-49

Wall Caps	50-51
-----------	-------

## FIRE PITS

Round Fire Pit Kit	52
Square Fire Pit Kit	53

## RESOURCES

Pallet Overviews	54-56
Color Matrix	57
Color Chart	58
Product Warranty	59



# Find your authorized contractor today



Simply open the camera app on your phone and scan the code to get in touch with our contractors.

Our goal is to provide you with quality paver & wall products for your project. We understand that it's a large investment. If you need help with finding the right contractor for your project, we can help. Our goal is to recommend qualified, knowledgeable hardscape contractors. The hardscape contractors found on our Keystone Authorized Contractor list have shown a proven knowledge on the basics of paver and retaining wall construction and installation. Each company listed has at least one individual on staff that has attended our two-day training course and passed our Installer Exam.

While we try our best to recommend qualified contractors for your project, Keystone does not guarantee the workmanship of the installer. Please ask your selected contractor for references and about any warranty or guarantees they might provide on workmanship.

## FOLLOW THESE STEPS TO SELECT THE IDEAL CONTRACTOR TO BRING YOUR PROJECT TO LIFE.

### STEP ONE

It's always a good idea to interview several contractors and find the best match for your project and personality. The contractor you choose will be at your project for days or weeks. Talk about working hours, how many people to expect at the project, what kind of equipment they will be using. Make sure you have a good rapport with the person and communicate your wants and needs.

**Make sure to ask if they are a Keystone Hardscapes Authorized Contractor.**

### STEP THREE

Once you reward the project to a specific contractor, get a written contract of the work to be performed. Make sure you understand the scope of your project and that any changes midway through the project, could result in additional costs to the project.

### STEP TWO

Once you decide on the work you want to complete, confirm that the contractor has done that type of work in the past. Ask for pictures, references, or go by other projects they have completed and make sure you are happy with their quality of work.

### STEP FOUR

Once your project is complete, we would love to see finished photos! Photos can be submitted to Keystone Hardscapes at [photos@keystonehardscapes.com](mailto:photos@keystonehardscapes.com). Photos may be used in social media or future catalog publications.

# Utilize our network of authorized contractors to build your happy place

We have a valued distributor network throughout the country who are knowledgeable about our products and have our products on display. We take great pride in providing in-depth regional training programs for contractors to become Authorized Keystone Contractors.

[Learn more at keystonehardscapes.com](https://www.keystonehardscapes.com)



FIND YOUR DEALER OR CONTRACTOR

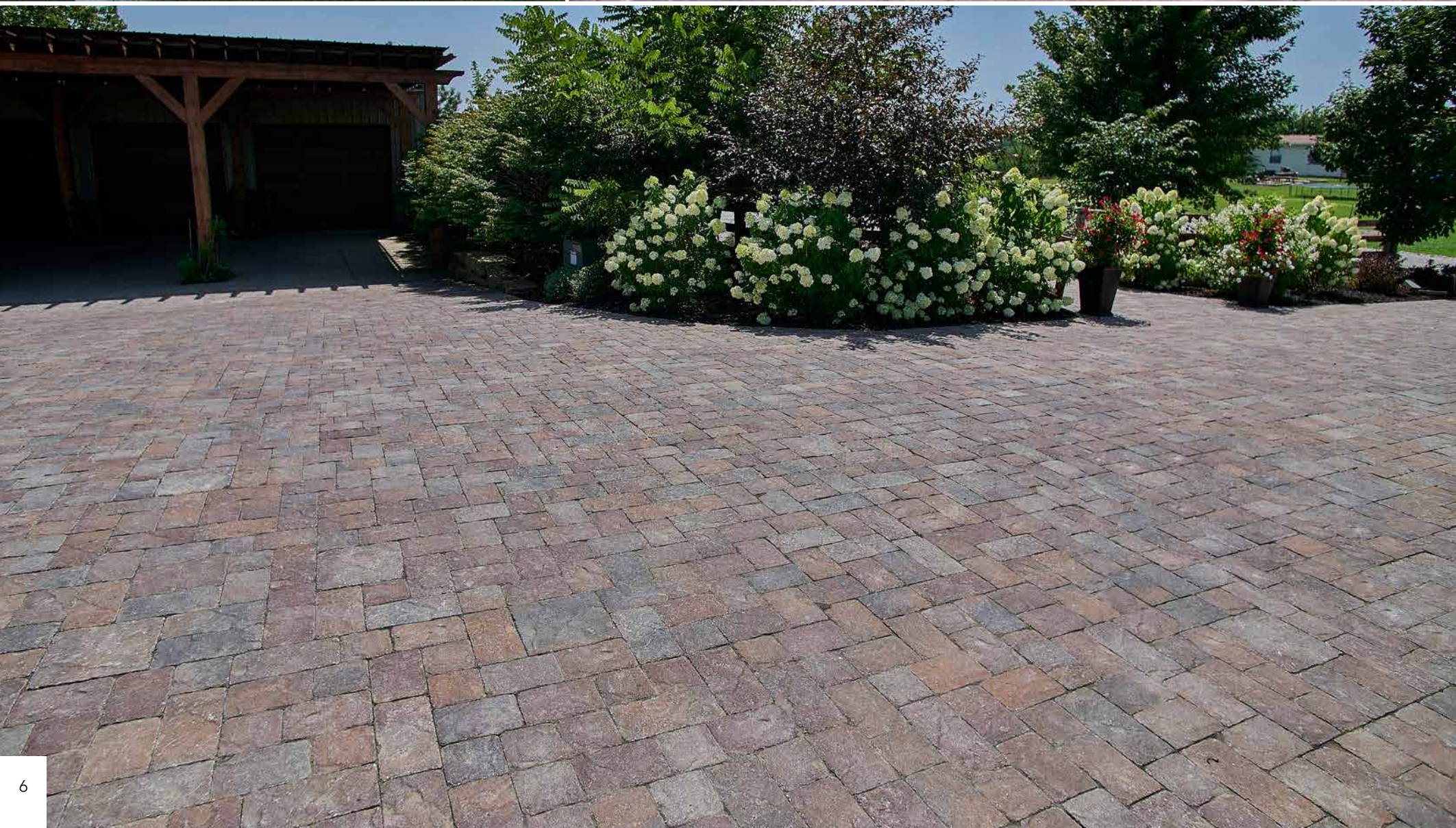

# LASTING MEMORIES HAPPEN HERE

## PAVERS

CITYSTONE™ DEMI & SUPRA

PANORAMA™ DEMI & SUPRA

VENETIAN®

VENETIAN®- TUMBLED

VENETIAN® FLAG

VINTAGE STONE®

VINTAGE STONE® - TUMBLED

HOLLAND STONE

CITYSCAPE ADA PAVER

CITYSTONE™ 4X4







GLACIER BLEND

# CITYSTONE™ | Demi & Supra

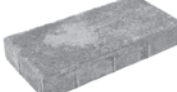

CityStone pavers deliver a sleek, modern style and sophistication. CityStone Demi & Supra can be installed as stand-alone three-piece, or a combined a six-piece, paving system.

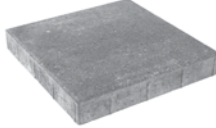

	<b>4x8</b> 3 <sup>15</sup> / <sub>16</sub> " x 7 <sup>7</sup> / <sub>8</sub> " x 2 <sup>3</sup> / <sub>8</sub> "		<b>8x16</b> 7 <sup>7</sup> / <sub>8</sub> " x 15 <sup>3</sup> / <sub>4</sub> " x 2 <sup>3</sup> / <sub>8</sub> "
	<b>8x8</b> 7 <sup>7</sup> / <sub>8</sub> " x 7 <sup>7</sup> / <sub>8</sub> " x 2 <sup>3</sup> / <sub>8</sub> "		<b>16x16</b> 15 <sup>3</sup> / <sub>4</sub> " x 15 <sup>3</sup> / <sub>4</sub> " x 2 <sup>3</sup> / <sub>8</sub> "
	<b>8x12</b> 7 <sup>7</sup> / <sub>8</sub> " x 11 <sup>13</sup> / <sub>16</sub> " x 2 <sup>3</sup> / <sub>8</sub> "		<b>16x24</b> 15 <sup>3</sup> / <sub>4</sub> " x 23 <sup>5</sup> / <sub>8</sub> " x 2 <sup>3</sup> / <sub>8</sub> "
#363 Demi - Bundle <sup>1,2</sup>		#364 Supra - Bundle <sup>1</sup>	

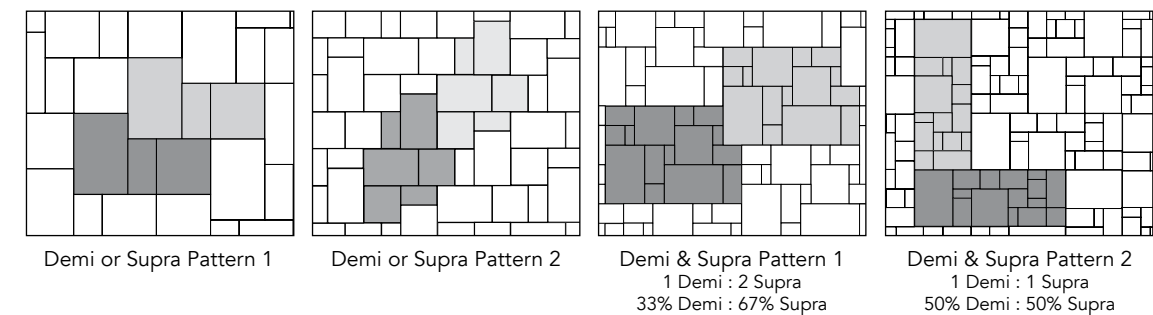

Product No.	Height	Dimensions	Units/Pallet	Pallet Weight	Sq.Ft./Pallet
#363	60mm	3 <sup>15</sup> / <sub>16</sub> " x 7 <sup>7</sup> / <sub>8</sub> " x 2 <sup>3</sup> / <sub>8</sub> "	80	2,826 lbs	103
	60mm	7 <sup>7</sup> / <sub>8</sub> " x 7 <sup>7</sup> / <sub>8</sub> " x 2 <sup>3</sup> / <sub>8</sub> "	80		
	60mm	7 <sup>7</sup> / <sub>8</sub> " x 11 <sup>13</sup> / <sub>16</sub> " x 2 <sup>3</sup> / <sub>8</sub> "	80		

Product No.	Height	Dimensions	Units/Pallet	Pallet Weight	Sq.Ft./Pallet
#364	60mm	7 <sup>7</sup> / <sub>8</sub> " x 15 <sup>3</sup> / <sub>4</sub> " x 2 <sup>3</sup> / <sub>8</sub> "	20	2,845 lbs	103
	60mm	15 <sup>3</sup> / <sub>4</sub> " x 15 <sup>3</sup> / <sub>4</sub> " x 2 <sup>3</sup> / <sub>8</sub> "	20		
	60mm	15 <sup>3</sup> / <sub>4</sub> " x 23 <sup>5</sup> / <sub>8</sub> " x 2 <sup>3</sup> / <sub>8</sub> "	20		

• Supra recommended for non-vehicular applications

Colors printed here are as true a match as the printing process will allow. For best matching results, please refer to actual samples. Not all products & colors are available in every plant.









EDDINGTON BLEND

# PANORAMA™ | Demi & Supra



Let this six-piece series bring your next hardscape design to life with sophistication and style. Panorama Demi & Supra can also be installed as two stand-alone three-piece paving systems.



	<b>4x8</b> 3 <sup>15</sup> / <sub>16</sub> " x 7 <sup>7</sup> / <sub>8</sub> " x 2 <sup>3</sup> / <sub>8</sub> "		<b>8x16</b> 7 <sup>7</sup> / <sub>8</sub> " x 15 <sup>3</sup> / <sub>4</sub> " x 2 <sup>3</sup> / <sub>8</sub> "
	<b>8x8</b> 7 <sup>7</sup> / <sub>8</sub> " x 7 <sup>7</sup> / <sub>8</sub> " x 2 <sup>3</sup> / <sub>8</sub> "		<b>16x16</b> 15 <sup>3</sup> / <sub>4</sub> " x 15 <sup>3</sup> / <sub>4</sub> " x 2 <sup>3</sup> / <sub>8</sub> "
	<b>8x12</b> 7 <sup>7</sup> / <sub>8</sub> " x 11 <sup>13</sup> / <sub>16</sub> " x 2 <sup>3</sup> / <sub>8</sub> "		<b>16x24</b> 15 <sup>3</sup> / <sub>4</sub> " x 23 <sup>5</sup> / <sub>8</sub> " x 2 <sup>3</sup> / <sub>8</sub> "
#367 Demi - Bundle <sup>1,2</sup>		#368 Supra - Bundle <sup>1</sup>	



Eddington Blend    Hearthstone Blend    Sand Blend    Trinity Blend

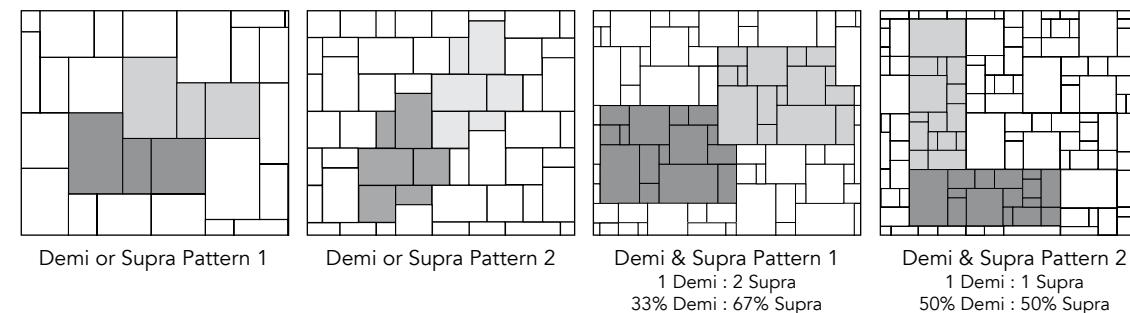

Product No.	Height	Dimensions	Units/Pallet	Pallet Weight	Sq.Ft./Pallet
#367	60mm	3 <sup>15</sup> / <sub>16</sub> " x 7 <sup>7</sup> / <sub>8</sub> " x 2 <sup>3</sup> / <sub>8</sub> "	80	2,826 lbs	103
	60mm	7 <sup>7</sup> / <sub>8</sub> " x 7 <sup>7</sup> / <sub>8</sub> " x 2 <sup>3</sup> / <sub>8</sub> "	80		
	60mm	7 <sup>7</sup> / <sub>8</sub> " x 11 <sup>13</sup> / <sub>16</sub> " x 2 <sup>3</sup> / <sub>8</sub> "	80		

Product No.	Height	Dimensions	Units/Pallet	Pallet Weight	Sq.Ft./Pallet
#368	60mm	7 <sup>7</sup> / <sub>8</sub> " x 15 <sup>3</sup> / <sub>4</sub> " x 2 <sup>3</sup> / <sub>8</sub> "	20	2,845 lbs	103
	60mm	15 <sup>3</sup> / <sub>4</sub> " x 15 <sup>3</sup> / <sub>4</sub> " x 2 <sup>3</sup> / <sub>8</sub> "	20		
	60mm	15 <sup>3</sup> / <sub>4</sub> " x 23 <sup>5</sup> / <sub>8</sub> " x 2 <sup>3</sup> / <sub>8</sub> "	20		

• Supra recommended for non-vehicular applications

Colors printed here are as true a match as the printing process will allow. For best matching results, please refer to actual samples. Not all products & colors are available in every plant.



WINTER BLEND

# VENETIAN®



A uniquely attractive textured surface sets Venetian apart from ordinary pavers, allowing for a dynamic interaction with sunlight and evoking the timeless beauty of flagstone. They are ideal for residential and commercial applications.



**6x6**  
5<sup>15</sup>/<sub>16</sub>" x 5<sup>15</sup>/<sub>16</sub>" x 2<sup>3</sup>/<sub>8</sub>"



**6x9**  
5<sup>15</sup>/<sub>16</sub>" x 8<sup>7</sup>/<sub>8</sub>" x 2<sup>3</sup>/<sub>8</sub>"



**#269 - 6x12**  
5<sup>15</sup>/<sub>16</sub>" x 11<sup>13</sup>/<sub>16</sub>" x 2<sup>3</sup>/<sub>8</sub>"



**#270 - 12x12**  
11<sup>13</sup>/<sub>16</sub>" x 11<sup>13</sup>/<sub>16</sub>" x 2<sup>3</sup>/<sub>8</sub>"

## #267 - Bundle



Granite Blend



Merriam Blend



Ozark Blend



Winter Blend

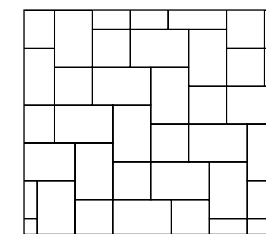

Herringbone  
6x6/6x9

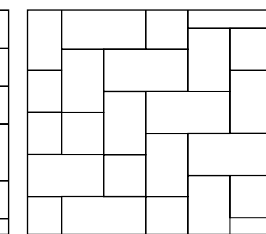

Herringbone  
6x6/6x9 (40%), 6x12 (60%)

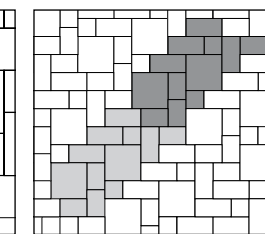

Random 4-pc  
6x6/6x9 (33%), 6x12 (33%),  
12x12 (33%)

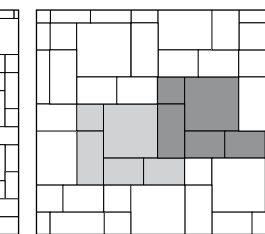

Random 4-pc  
6x6/6x9 (40%), 6x12 (20%),  
12x12 (40%)

Product No.	Height	Dimensions	Units/Pallet	Pallet Weight	Sq.Ft./Pallet
#267	60mm	5 <sup>15</sup> / <sub>16</sub> " x 5 <sup>15</sup> / <sub>16</sub> " x 2 <sup>3</sup> / <sub>8</sub> "	100	2,612 lbs	95
	60mm	5 <sup>15</sup> / <sub>16</sub> " x 8 <sup>7</sup> / <sub>8</sub> " x 2 <sup>3</sup> / <sub>8</sub> "	200		

Product No.	Height	Dimensions	Units/Pallet	Pallet Weight	Sq.Ft./Pallet
#269	60mm	5 <sup>15</sup> / <sub>16</sub> " x 11 <sup>13</sup> / <sub>16</sub> " x 2 <sup>3</sup> / <sub>8</sub> "	200	2,590 lbs	96

Product No.	Height	Dimensions	Units/Pallet	Pallet Weight	Sq.Ft./Pallet
#270	60mm	11 <sup>13</sup> / <sub>16</sub> " x 11 <sup>13</sup> / <sub>16</sub> " x 2 <sup>3</sup> / <sub>8</sub> "	120	3,134 lbs	120

Colors printed here are as true a match as the printing process will allow. For best matching results, please refer to actual samples. Not all products & colors are available in every plant.

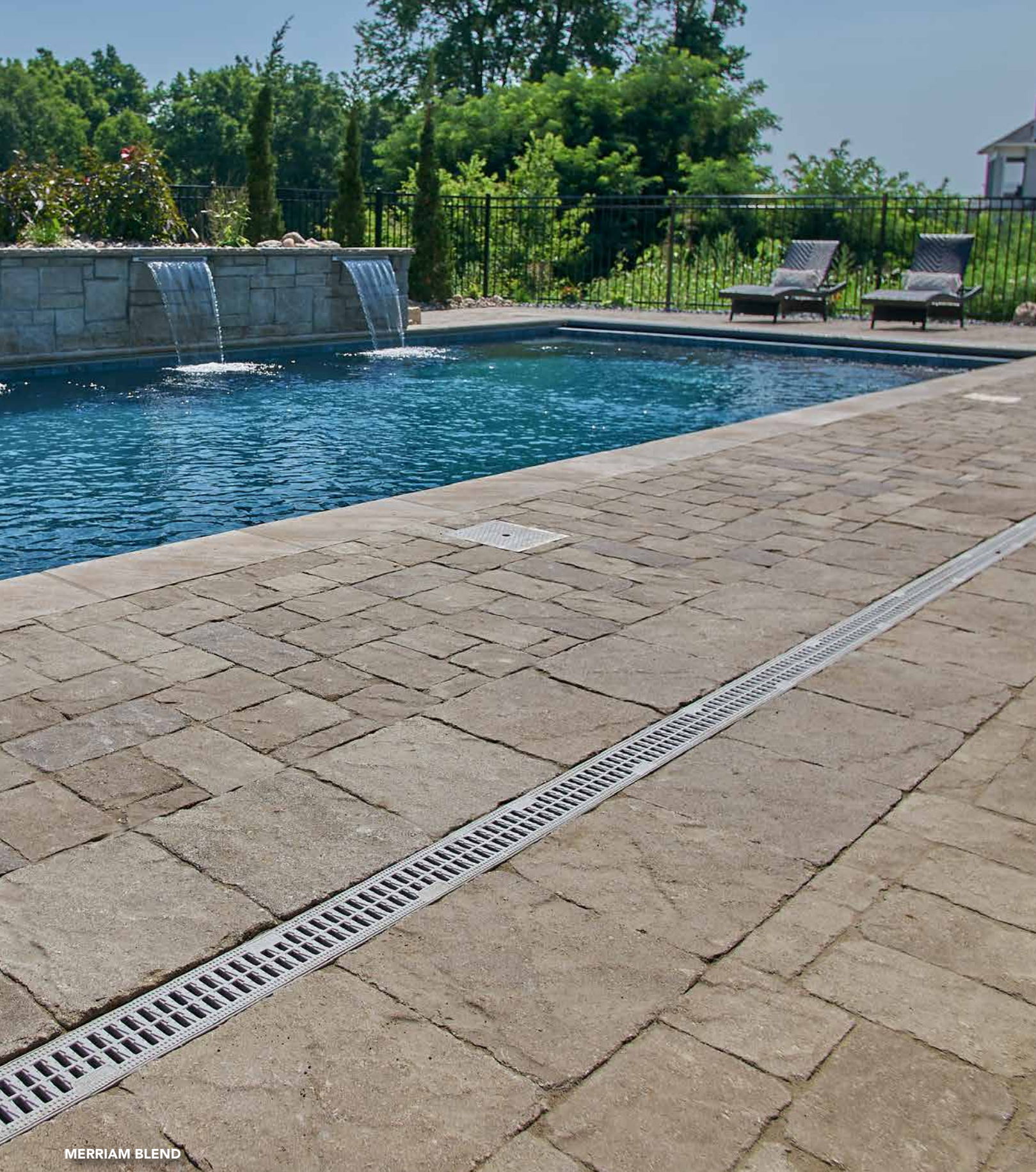

MERRIAM BLEND

# VENETIAN® | Tumbled



The larger scale of Venetian - Tumbled lends itself to stately residential settings and more expansive commercial applications. The tumbled texture evokes an Old World charm and grace.

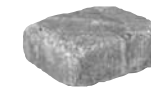

**6x6**  
5<sup>15</sup>/<sub>16</sub>" x 5<sup>15</sup>/<sub>16</sub>" x 2<sup>3</sup>/<sub>8</sub>"



**6x9**  
5<sup>15</sup>/<sub>16</sub>" x 8<sup>7</sup>/<sub>8</sub>" x 2<sup>3</sup>/<sub>8</sub>"



**#269T - 6x12**  
5<sup>15</sup>/<sub>16</sub>" x 11<sup>13</sup>/<sub>16</sub>" x 2<sup>3</sup>/<sub>8</sub>"



**#270T - 12x12**  
11<sup>13</sup>/<sub>16</sub>" x 11<sup>13</sup>/<sub>16</sub>" x 2<sup>3</sup>/<sub>8</sub>"

## #267T - Bundle



Granite Blend



Merriam Blend



Ozark Blend



Winter Blend

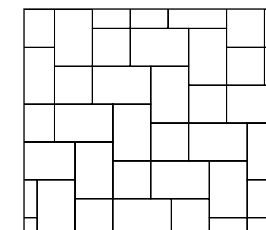

Herringbone  
6x6/6x9

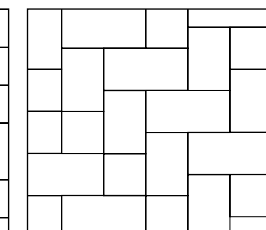

Herringbone  
6x6/6x9 (40%), 6x12 (60%)

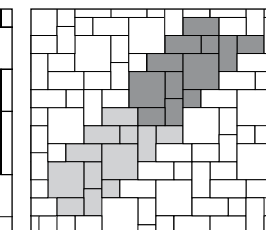

Random 4-pc  
6x6/6x9 (33%), 6x12 (33%),  
12x12 (33%)

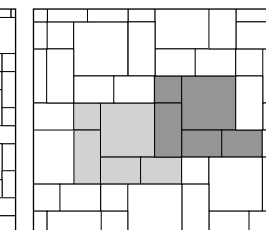

Random 4-pc  
6x6/6x9 (40%), 6x12 (20%),  
12x12 (40%)

Product No.	Height	Dimensions	Units/Pallet	Pallet Weight	Sq.Ft./Pallet
#267T	60mm	5 <sup>15</sup> / <sub>16</sub> " x 5 <sup>15</sup> / <sub>16</sub> " x 2 <sup>3</sup> / <sub>8</sub> "	100	2,612 lbs	95
	60mm	5 <sup>15</sup> / <sub>16</sub> " x 8 <sup>7</sup> / <sub>8</sub> " x 2 <sup>3</sup> / <sub>8</sub> "	200		

Product No.	Height	Dimensions	Units/Pallet	Pallet Weight	Sq.Ft./Pallet
#269T	60mm	5 <sup>15</sup> / <sub>16</sub> " x 11 <sup>13</sup> / <sub>16</sub> " x 2 <sup>3</sup> / <sub>8</sub> "	200	2,590 lbs	96

Product No.	Height	Dimensions	Units/Pallet	Pallet Weight	Sq.Ft./Pallet
#270T	60mm	11 <sup>13</sup> / <sub>16</sub> " x 11 <sup>13</sup> / <sub>16</sub> " x 2 <sup>3</sup> / <sub>8</sub> "	120	3,134 lbs	120

Colors printed here are as true a match as the printing process will allow. For best matching results, please refer to actual samples. Not all products & colors are available in every plant.





SAND BLEND

# VENETIAN® | Flag



Venetian Flag is perfect for the customer who desires the look of flagstone without the high cost. Irregular shapes and a textured surface create outdoor spaces that integrate seamlessly with their surroundings.

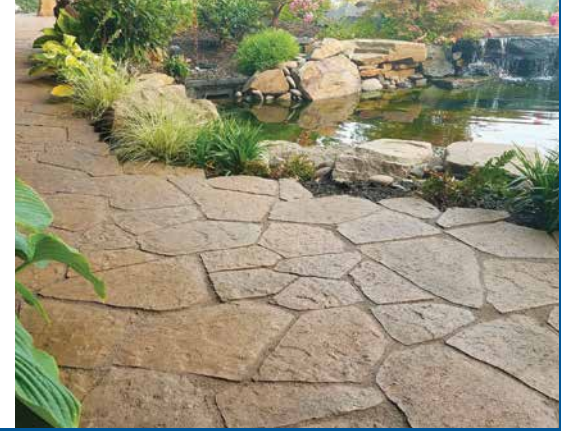

- Stone A**  
18" x 24" x 2<sup>3</sup>/<sub>8</sub>"
- Stone B**  
18" x 24" x 2<sup>3</sup>/<sub>8</sub>"
- Stone C**  
18" x 24" x 2<sup>3</sup>/<sub>8</sub>"
- Stone D**  
18" x 12" x 2<sup>3</sup>/<sub>8</sub>"
- Stone E**  
18" x 12" x 2<sup>3</sup>/<sub>8</sub>"

#369 - Bundle



Sand Blend

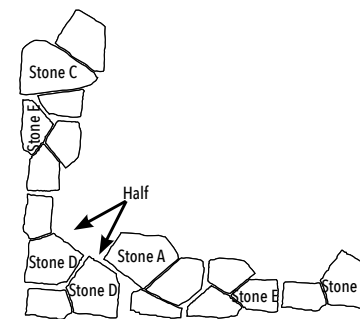

Corner & Edge Assembly #1

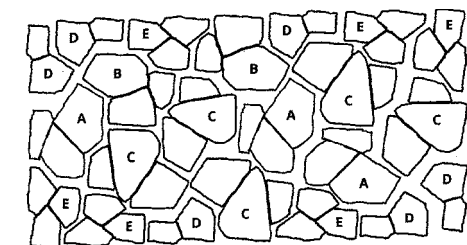
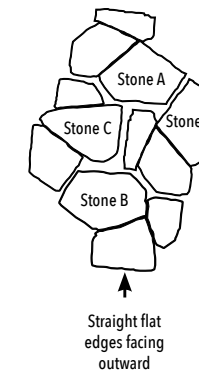

4' x 8' Installation

Product No.	Height	Dimensions	Units/Pallet	Pallet Weight	Sq.Ft./Pallet
#369	60mm	A: 18" x 24" x 2 <sup>3</sup> / <sub>8</sub> "	10	2,100 lbs	80
	60mm	B: 18" x 24" x 2 <sup>3</sup> / <sub>8</sub> "	10		
	60mm	C: 18" x 24" x 2 <sup>3</sup> / <sub>8</sub> "	10		
	60mm	D: 18" x 12" x 2 <sup>3</sup> / <sub>8</sub> "	10		
	60mm	E: 18" x 12" x 2 <sup>3</sup> / <sub>8</sub> "	10		

Colors printed here are as true a match as the printing process will allow. For best matching results, please refer to actual samples. Not all products & colors are available in every plant.



MERRIAM BLEND

# VINTAGE STONE®



The Vintage Stone product line delivers scale, color, and modular design options for unique pavement expressions. Its design versatility make it one of our most popular pavers.

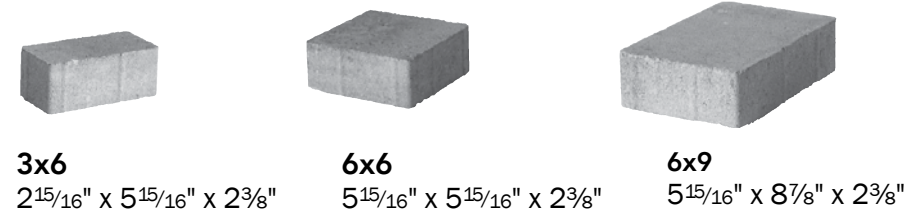

**3x6**  
2<sup>15</sup>/<sub>16</sub>" x 5<sup>15</sup>/<sub>16</sub>" x 2<sup>3</sup>/<sub>8</sub>"

**6x6**  
5<sup>15</sup>/<sub>16</sub>" x 5<sup>15</sup>/<sub>16</sub>" x 2<sup>3</sup>/<sub>8</sub>"

**6x9**  
5<sup>15</sup>/<sub>16</sub>" x 8<sup>7</sup>/<sub>8</sub>" x 2<sup>3</sup>/<sub>8</sub>"

#293 - Bundle

#293 - 3-pc



Merriam Blend      Ozark Blend      Winter Blend

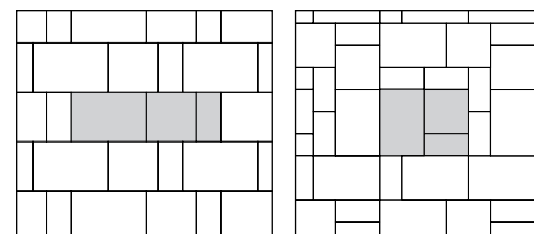

Runner Bond  
3x6/6x6/6x9

Random without 9x9  
3x6/6x6 (40%) 6x9 (60%)

Product No.	Height	Dimensions	Units/Pallet	Pallet Weight	Sq.Ft./Pallet
#293	60mm	2 <sup>15</sup> / <sub>16</sub> " x 5 <sup>15</sup> / <sub>16</sub> " x 2 <sup>3</sup> / <sub>8</sub> "	160	3,210 lbs	116
	60mm	5 <sup>15</sup> / <sub>16</sub> " x 5 <sup>15</sup> / <sub>16</sub> " x 2 <sup>3</sup> / <sub>8</sub> "	160		
	60mm	5 <sup>15</sup> / <sub>16</sub> " x 8 <sup>7</sup> / <sub>8</sub> " x 2 <sup>3</sup> / <sub>8</sub> "	160		

Colors printed here are as true a match as the printing process will allow. For best matching results, please refer to actual samples. Not all products & colors are available in every plant.



MERRIAM BLEND

# VINTAGE STONE® | Tumbled



Providing an Old World charm and grace, the Vintage Stone product is also available in a tumbled texture.



**3x6**  
2<sup>15</sup>/<sub>16</sub>" x 5<sup>15</sup>/<sub>16</sub>" x 2<sup>3</sup>/<sub>8</sub>"



**6x6**  
5<sup>15</sup>/<sub>16</sub>" x 5<sup>15</sup>/<sub>16</sub>" x 2<sup>3</sup>/<sub>8</sub>"



**6x9**  
5<sup>15</sup>/<sub>16</sub>" x 8<sup>7</sup>/<sub>8</sub>" x 2<sup>3</sup>/<sub>8</sub>"

#293T - Bundle



Merriam Blend



Ozark Blend



Winter Blend

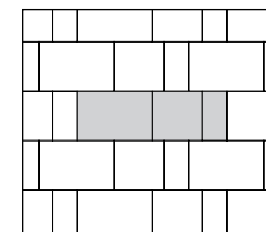

Runner Bond  
3x6/6x6/6x9

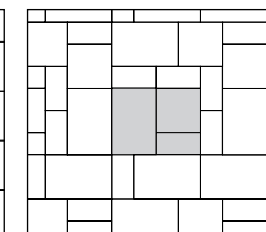

Random without 9x9  
3x6/6x6 (40%) 6x9 (60%)

Product No.	Height	Dimensions	Units/Pallet	Pallet Weight	Sq.Ft./Pallet
#293T	60mm	2 <sup>15</sup> / <sub>16</sub> " x 5 <sup>15</sup> / <sub>16</sub> " x 2 <sup>3</sup> / <sub>8</sub> "	160	3,210 lbs	116
	60mm	5 <sup>15</sup> / <sub>16</sub> " x 5 <sup>15</sup> / <sub>16</sub> " x 2 <sup>3</sup> / <sub>8</sub> "	160		
	60mm	5 <sup>15</sup> / <sub>16</sub> " x 8 <sup>7</sup> / <sub>8</sub> " x 2 <sup>3</sup> / <sub>8</sub> "	160		

Colors printed here are as true a match as the printing process will allow. For best matching results, please refer to actual samples. Not all products & colors are available in every plant.



CHARCOAL

# HOLLAND STONE



Holland Stone offers the charm and versatility of a simple rectangular shape. From simplistic to intricate, pattern options are almost endless. Maximize design potential by combining pattern and color options.



#217 - 60mm<sup>1</sup>  
 $3^{15}/16" \times 7^{7}/8" \times 2^{3}/8"$



Antique Red      Charcoal

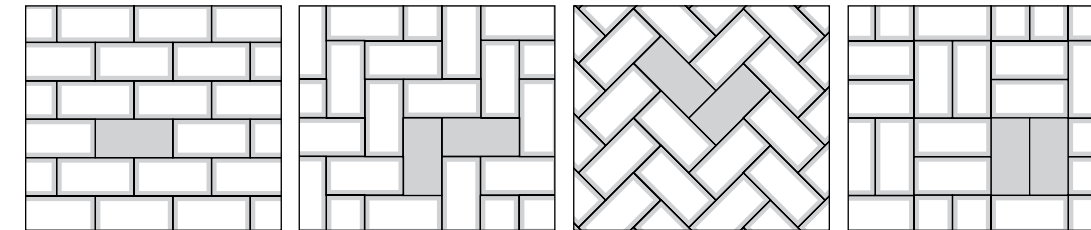

Runner Bond      90° Herringbone      45° Herringbone      Parquet

Product No.	Height	Dimensions	Units/Pallet	Pallet Weight	Sq.Ft./Pallet
#217	60mm	$3^{15}/16" \times 7^{7}/8" \times 2^{3}/8"$	480	2,766 lbs	103

Colors printed here are as true a match as the printing process will allow. For best matching results, please refer to actual samples. Not all products & colors are available in every plant.



RIVER RED

# CITYSCAPE ADA

## Detectable Warning Paver



The ADA Detectable Warning paver provides visual and textural guidance provisions for wheelchair and pedestrian access to streets, sidewalks and other components of the public right of way.



PAVERS



#200

3<sup>15</sup>/<sub>16</sub>" x 7<sup>7</sup>/<sub>8</sub>" x 2<sup>3</sup>/<sub>8</sub>"



River Red

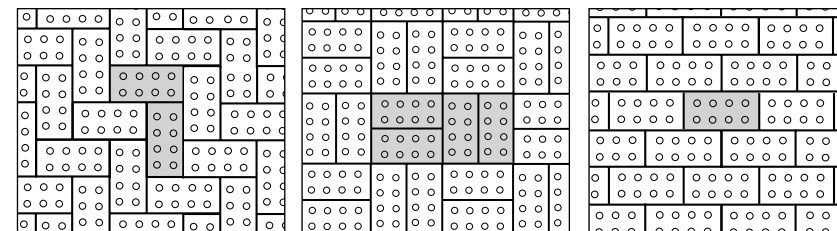

Herringbone

Parquet

Runner Bond

Product No.	Height	Dimensions	Units/Pallet	Pallet Weight	Sq.Ft./Pallet
#200	60mm	3 <sup>15</sup> / <sub>16</sub> " x 7 <sup>7</sup> / <sub>8</sub> " x 2 <sup>3</sup> / <sub>8</sub> "	480	2,823 lbs	103

Colors printed here are as true a match as the printing process will allow. For best matching results, please refer to actual samples. Not all products & colors are available in every plant.



PEWTER

# CITYSTONE™ | 4X4



City Stone 4x4 brings scale and dimension to architectural settings. City Stone 4x4 can be used alone or in combination modules of symmetrical square shapes to create extraordinary patterns.



PAVERS



**#213**  
 $3\frac{15}{16}'' \times 3\frac{15}{16}'' \times 2\frac{3}{8}''$



Pewter

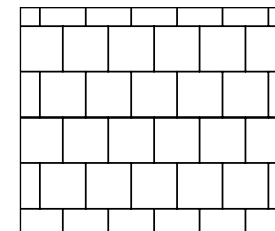

Runner Bond

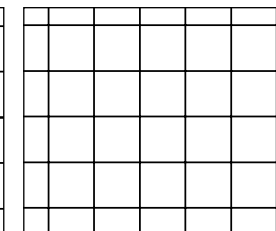

Stack Bond

Product No.	Height	Dimensions	Units/Pallet	Pallet Weight	Sq.Ft./Pallet
#213	60mm	$3\frac{15}{16}'' \times 3\frac{15}{16}'' \times 2\frac{3}{8}''$	960	2,847 lbs	103

Colors printed here are as true a match as the printing process will allow. For best matching results, please refer to actual samples. Not all products & colors are available in every plant.

# INSPIRING SPACES



## STRUCTURAL WALLS

REGAL STONE PRO® - MEDLEY

REGAL STONE PRO® - ROCKFACE

REGAL STONE PRO® - TRI-PLANE

## LANDSCAPE WALLS

HARINGTON® 3-PC

HARINGTON® MEDLEY

HARINGTON® FREESTANDING 3-PC

RUMBLED WALL™

STONEGATE® - OLD WORLD

STONEGATE® - CONTEMPORARY

12 INCH RETAINING WALL

## WALL CAPS

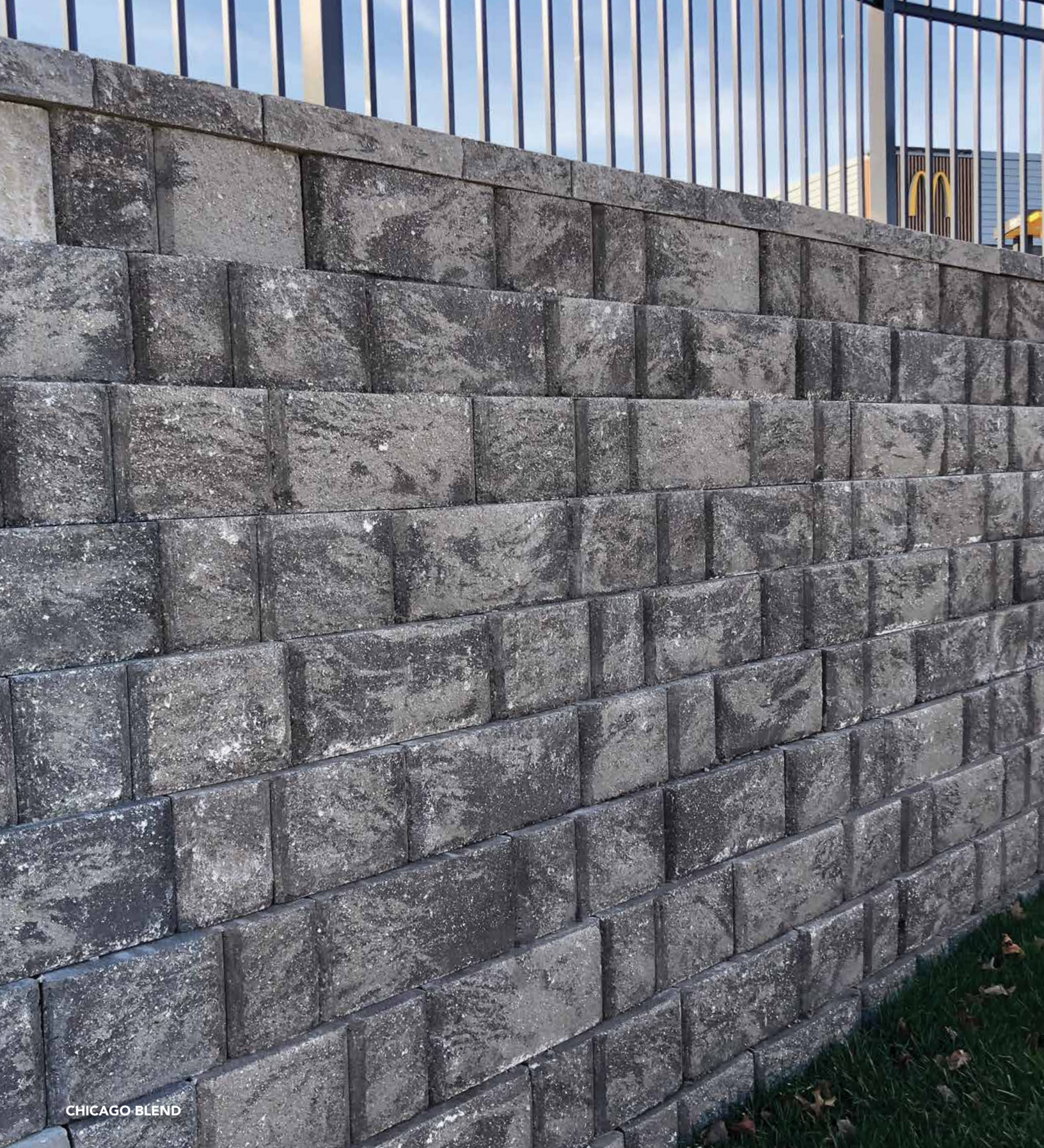

# REGAL STONE PRO® | Medley



Featuring easy rear lip installation, Regal Stone Pro - Medley's scored and straight split faces are combined to achieve a three-piece aesthetic with the efficiencies of a single unit installation.



**Left Score**  
8" x 18" x 12"



**Solid**  
8" x 18" x 12"



**Right Score**  
8" x 18" x 12"

**#888 Bundle**



Chicago Blend



Ozark Blend



Sand Blend

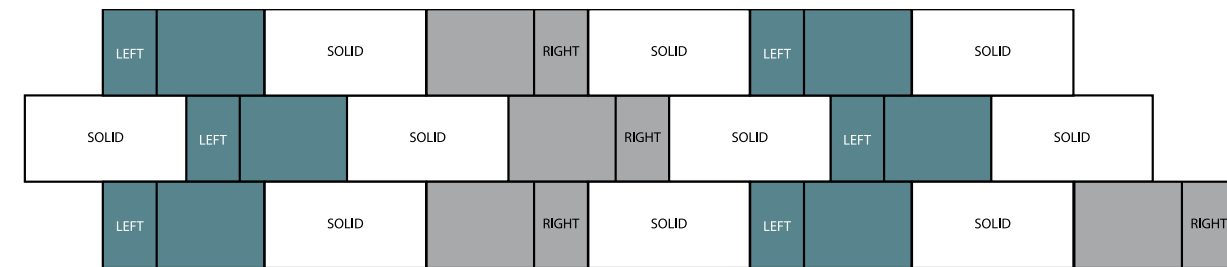

Product No.	Height	Width	Depth	Units/Pallet	Pallet Weight	Face Ft./Pallet	Batter
#888	8"	18"	12"	9 (Left Score)	2,980 lbs	36	7.1°
	8"	18"	12"	18 (Solid)			
	8"	18"	12"	9 (Right Score)			

Colors printed here are as true a match as the printing process will allow. For best matching results, please refer to actual samples. Not all products & colors are available in every plant.





SAND BLEND

# REGAL STONE PRO® | RockFace



This full one-square-foot face features a natural stone texture, making it a distinctive addition to any landscape. The hollow core helps lighten the unit for easy handling.



**#818 - RockFace**  
8" x 18" x 12"



**#110865 - 8" Straight Corner**  
8" x 18" x 9"

#818 - RockFace



Chicago Blend

Ozark Blend

Sand Blend

Pewter

Savannah

#110865 - 8" Straight Corner



Chicago Blend

Ozark Blend

Sand Blend

Pewter

Savannah

Product No.	Height	Width	Depth	Units/Pallet	Pallet Weight	Face Ft./Pallet	Batter
#818	8"	18"	12"	36	3,024 lbs	36	7.1°

Product No.	Height	Width	Depth	Units/Pallet	Pallet Weight	Face Ft./Pallet
#110865	8"	18"	9"	40	4,333 lbs	60

Colors printed here are as true a match as the printing process will allow. For best matching results, please refer to actual samples. Not all products & colors are available in every plant.



PEWTER

# REGAL STONE PRO® | Tri-Plane



Regal Stone Pro provides a proven solution for commercial and residential applications. Its dependable and easy rear lip installation make this unit an attractive and cost effective retaining wall system.



#826 - Tri-Plane  
8" x 18" x 12"



Pewter



Savannah

Product No.	Height	Width	Depth	Units/Pallet	Pallet Weight	Face Ft./Pallet	Batter
#826	8"	18"	12"	36	2,814 lbs	36	7.1°

Colors printed here are as true a match as the printing process will allow. For best matching results, please refer to actual samples. Not all products & colors are available in every plant.



CHICAGO BLEND

# HARINGTON® | 3-pc and Large



The Harington 3-piece wall system evokes the look and feel of natural hand-hewn stone, making a striking design statement while the rear lip feature eliminates setback and alignment issues to speed construction.



WALLS



**Small**  
6" x 6" x 12"



**Medium**  
6" x 12" x 12"



**Large**  
6" x 18" x 12"



**#883 - Large**  
6" x 18" x 12"

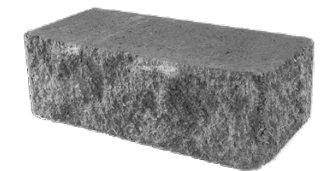

**#110894 - 6in RockFace Corner**  
6" x 18" x 9"

**#876 Bundle**

#876 - 3pc and #110894 6in Corner



Chicago Blend



Merriam Blend



Ozark Blend



Sand Blend

#883 - Large



Chicago Blend



Merriam Blend



Ozark Blend



Sand Blend



Pewter



Savannah

Product No.	Height	Width	Depth	Units/Pallet	Pallet Weight	Face Ft./Pallet	Batter
#876	6"	6"	12"	20	3,395 lbs	30	10.6°
	6"	12"	12"	20			
	6"	18"	12"	20			

Product No.	Height	Width	Depth	Units/Pallet	Pallet Weight	Face Ft./Pallet	Batter
#883	6"	18"	12"	45	3,924 lbs	33.8	10.6°

Product No.	Height	Width	Depth	Units/Pallet	Pallet Weight	Face Ft./Pallet
#110894	6"	18"	9"	40	3,275 lbs	45

Colors printed here are as true a match as the printing process will allow. For best matching results, please refer to actual samples. Not all products & colors are available in every plant.



SAND BLEND

# HARINGTON® | Medley

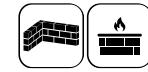

Left Score  
6" x 18" x 12"

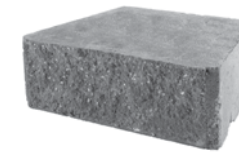

Straight  
6" x 18" x 12"



Right Score  
6" x 18" x 12"

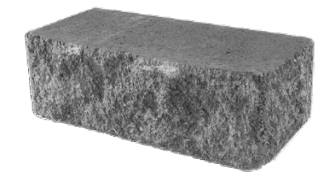

#110894 - 6in  
RockFace Corner  
6" x 18" x 9"

#87078 - Medley Bundle



Chicago Blend



Merriam Blend



Ozark Blend



Sand Blend

Product No.	Height	Width	Depth	Units/Pallet	Pallet Weight	Face Ft./Pallet	Batter
#870	6"	18"	12"	11 (Left)	3,924 lbs	33.8	10.6
	6"	18"	12"	23 (Solid)			
	6"	18"	12"	11 (Right)			

Product No.	Height	Width	Depth	Units/Pallet	Pallet Weight	Face Ft./Pallet
#110894	6"	18"	9"	40	3,275 lbs	45

Colors printed here are as true a match as the printing process will allow. For best matching results, please refer to actual samples. Not all products & colors are available in every plant.



MERRIAM BLEND

# HARINGTON®

## Freestanding 3-Piece

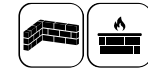

The Harington Freestanding 3-piece wall is crafted in compelling colors and rough-hewn textures. Create curved or straight freestanding walls, columns, outdoor kitchens and fire features with this versatile system.



**Small**  
6" x 6"/4" x 9"



**Medium**  
6" x 12"/10" x 9"

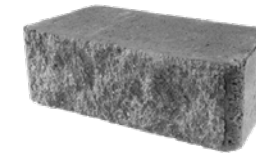

**Large**  
6" x 18"/16" x 9"

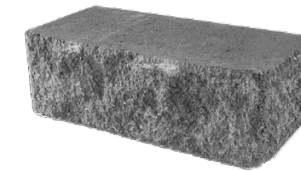

**#110894 - 6" RockFace Corner**  
6" x 18" x 9"

#889N Bundle



Chicago Blend



Merriam Blend



Ozark Blend



Sand Blend

Product No.	Height	Width	Depth	Units/Pallet	Pallet Weight	Face Ft./Pallet	Batter
#889N	6"	6"/4"	9"	20	2,960 lbs	28	N/A
	6"	12"/10"	9"	20			
	6"	18"/16"	9"	20			
Product No.	Height	Width	Depth	Units/Pallet	Pallet Weight	Face Ft./Pallet	
#110894	6"	18"	9"	40	3,275 lbs	45	

Colors printed here are as true a match as the printing process will allow. For best matching results, please refer to actual samples. Not all products & colors are available in every plant.



SAND BLEND

# RUMBLED WALL™

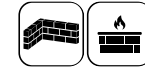

Rumbled Wall provides rustic building blocks for do-it-yourself hardscape projects. Its weathered appearance offers a natural look and feel, adding texture and depth to raised planting beds, fire pits, columns, and seat walls.



#519  
4" x 16" x 8"



Chicago Blend



Merriam Blend



Ozark Blend



Sand Blend

Product No.	Height	Width	Depth	Units/Pallet	Pallet Weight	Face Ft./Pallet	Batter
#519	4"	16"	8"	70	2,965 lbs	31	N/A

Colors printed here are as true a match as the printing process will allow. For best matching results, please refer to actual samples. Not all products & colors are available in every plant.



EDDINGTON BLEND

# STONEGATE® | Old World

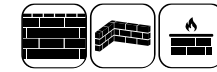

Reminiscent of the charming walls of the European countryside, Stonegate features a smoothly weathered stone appearance, perfect for outdoor living projects, freestanding and retaining walls.



WALLS



**Small**  
6" x 6"/4" x 10"



**Medium**  
6" x 12"/10" x 10"



**Large**  
6" x 16"/14" x 10"



**#110177T - Cap**  
3" x 12"/10" x 11"



2 Connection pins required per unit.

**#110176T Bundle**



Eddington Blend



Granite Blend



Hearthstone Blend

Product No.	Height	Width	Depth	Units/Pallet	Pallet Weight	Face Ft./Pallet	Batter
#110176T	6"	6"/4"	10"	20	2,925 lbs	26 (approx)	N/A Middle Pin 9.6° Outside Pin
	6"	12"/10"	10"	20			
	6"	16"/14"	10"	20			

Product No.	Height	Width	Depth	Units/Pallet	Pallet Weight	Lin. Ft./Pallet	Lin. Ft./Cap
#110177T	3"	12"/10"	11"	120	3,579 lbs	110	.92

Colors printed here are as true a match as the printing process will allow. For best matching results, please refer to actual samples. Not all products & colors are available in every plant.



GRANITE BLEND

# STONEGATE® | Contemporary

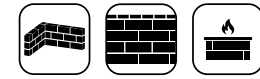

Stonegate is a smooth-faced versatile wall system that allows for the easy creation of gravity walls up to 3-feet in height, freestanding walls and outdoor living elements such as outdoor kitchens, fireplaces, fire pits and benches.



WALLS

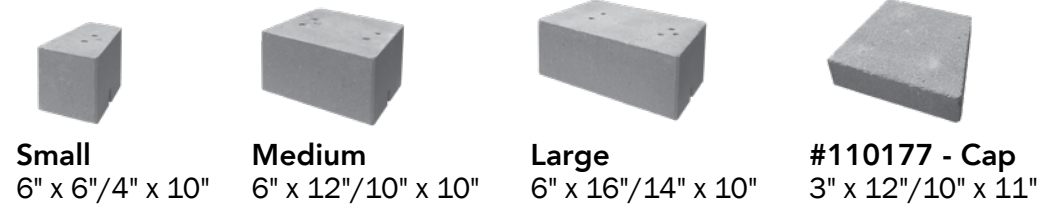

**Small** 6" x 6"/4" x 10"  
**Medium** 6" x 12"/10" x 10"  
**Large** 6" x 16"/14" x 10"  
**#110177 - Cap** 3" x 12"/10" x 11"

..... **#110176 Bundle** .....



Eddington Blend Granite Blend Hearthstone Blend

Product No.	Height	Width	Depth	Units/Pallet	Pallet Weight	Face Ft./Pallet	Batter
#110176	6"	6"/4"	10"	20	2,925 lbs	26 (approx)	N/A Middle Pin 9.6° Outside Pin
	6"	12"/10"	10"	20			
	6"	16"/14"	10"	20			
Product No.	Height	Width	Depth	Units/Pallet	Pallet Weight	Lin. Ft./Pallet	Lin. Ft./Cap
#110177	3"	12"/10"	11"	120	3,579 lbs	110	.92

Colors printed here are as true a match as the printing process will allow. For best matching results, please refer to actual samples. Not all products & colors are available in every plant.





MERRIAM BLEND

# 12" RETAINING WALL



The perfect complement to residential landscape design, Retaining Walls are a beautiful solution for any project from garden beds and tree rings to curved walls and terraces.



WALLS



**#811**  
4" x 11<sup>5</sup>/<sub>8</sub>" x 6<sup>3</sup>/<sub>4</sub>"



**#814 - Cap**  
2" x 11<sup>7</sup>/<sub>8</sub>" x 8"

## #811 - 12" Retaining Wall



Merriam Blend



Oaks Blend



Pecan



Pewter



River Red



Savannah



Terra Cotta



Winter Blend

## #814 - 12" Retaining Wall Cap



Pewter



Savannah

Product No.	Height	Width	Depth	Units/Pallet	Pallet Weight	Face Ft./Pallet	Batter
#811	4"	11 <sup>5</sup> / <sub>8</sub> "	6 <sup>3</sup> / <sub>4</sub> "	144	3,161 lbs	48	10.6°

Product No.	Height	Width	Depth	Units/Pallet	Pallet Weight	Lin. Ft./Pallet	Lin. Ft./Cap
#814	2"	11 <sup>7</sup> / <sub>8</sub> "	8"	120	1,889 lbs	113	0.99

Colors printed here are as true a match as the printing process will allow. For best matching results, please refer to actual samples. Not all products & colors are available in every plant.

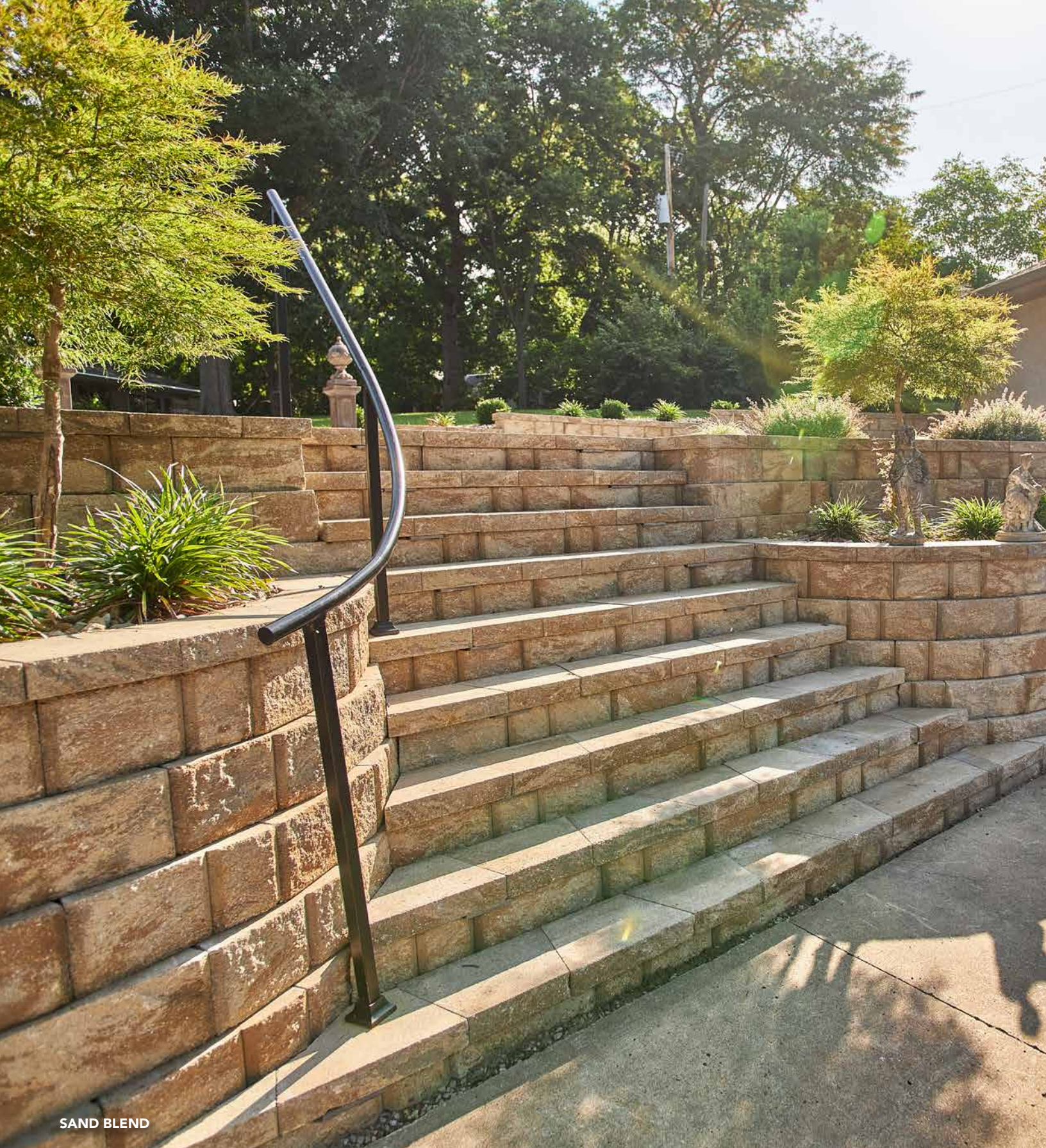

SAND BLEND

# WALL CAPS

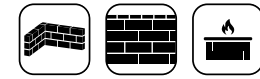

The perfect complement to residential landscape design, Retaining Walls are a beautiful solution for any project from garden beds and tree rings to curved walls and terraces.



**#817 - 3" Trapezoid Cap**  
3" x 18"/12" x 11"

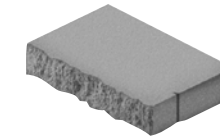

**#110819 - 3" Rectangle Cap**  
3" x 18" x 13½"



**#830 - 4" Trapezoid Cap**  
4" x 17½"/12" x 10⅝"

#817 - 3" Trapezoid Cap



Chicago Blend



Merriam Blend



Ozark Blend



Sand Blend

#110819 - 3" Rectangle Cap



Chicago Blend



Merriam Blend



Ozark Blend



Sand Blend



Pewter



Savannah

#830 - 4" Trapezoid Cap



Chicago Blend



Ozark Blend



Sand Blend



Pewter



Savannah

Product No.	Height	Width	Depth	Units/Pallet	Pallet Weight	Lin. Ft./Pallet	Lin. Ft./Cap
#817	3"	18"/12"	11"	72	2,924 lbs	90	1.25

Product No.	Height	Width	Depth	Units/Pallet	Pallet Weight	Lin. Ft./Pallet	Lin. Ft./Cap
#110819	3"	18"	13½"	48	2,905 lbs	72	1.5

Product No.	Height	Width	Depth	Units/Pallet	Pallet Weight	Lin. Ft./Pallet	Lin. Ft./Cap
#830	4"	17½"/12"	10⅝"	63	3,137 lbs	76	1.2

Colors printed here are as true a match as the printing process will allow. For best matching results, please refer to actual samples. Not all products & colors are available in every plant.

# ROUND FIRE PIT KIT

## Harington® Freestanding

Nothing compares with the simple, timeless appeal of a fire pit; offering a gathering place for family and friends.



# SQUARE FIRE PIT KIT

## Rumbled Wall™

A Fire Pit Kit makes a great weekend project that can create a space for the best of memories.



Chicago Blend Merriam Blend Ozark Blend Sand Blend

Dimensions	Included	Product Numbers
48" Outside Diameter x 30" Inside Diameter	48 pieces Harington Freestanding Small, 11 precut caps and insert with grate	#496-RPT

Insert with grate can be purchased separately - #417-JAP-11284

WARNING: Combustion byproducts produced when using this product include carbon monoxide, a chemical known to the State of California to cause birth defects or other reproductive harm.



Chicago Blend Merriam Blend Ozark Blend Sand Blend

Dimensions	Included	Product Number
40" Outside Diameter x 24" Inside Diameter	32 pieces of Rumbled Wall rectangles, and insert with grate	#496-SPT

Insert with grate can be purchased separately - #417-JAP-14181

WARNING: Combustion byproducts produced when using this product include carbon monoxide, a chemical known to the State of California to cause birth defects or other reproductive harm.

# PALLET OVERVIEW | by Paver

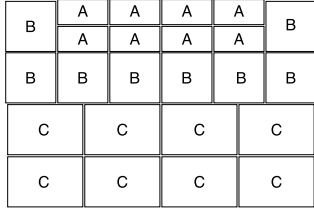
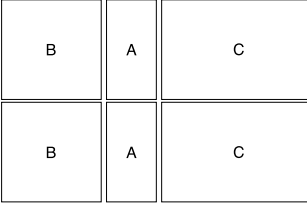
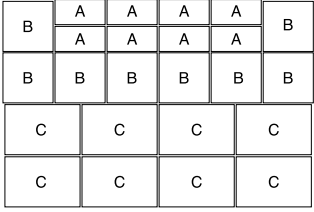
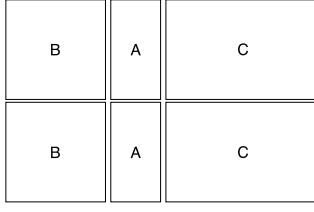
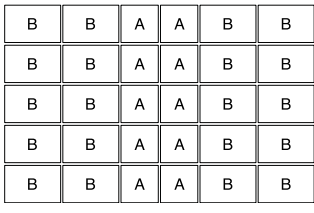
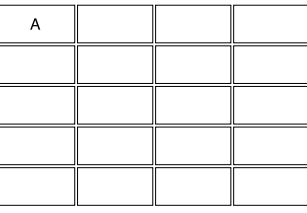
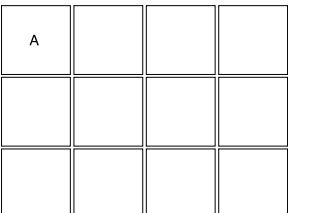
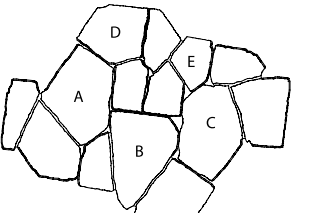
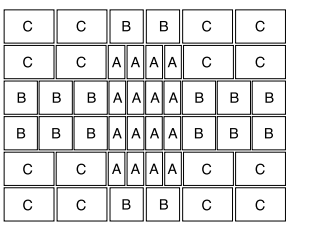
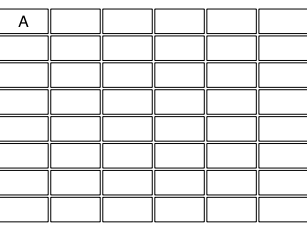
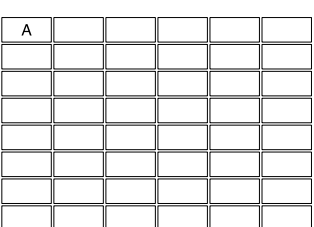
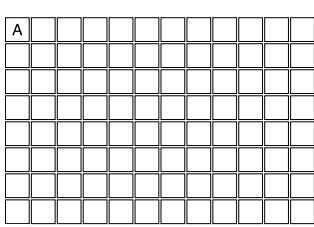
<p><b>#363</b> CityStone™ Demi Pieces per layer: 24 Layers per pallet: 10 Sq. ft. per pallet: 103</p> 	<p><b>#364</b> CityStone™ Supra Pieces per layer: 6 Layers per pallet: 10 Sq. ft. per pallet: 103</p> 	<p><b>#367</b> Panorama™ Demi Pieces per layer: 24 Layers per pallet: 10 Sq. ft. per pallet: 103</p> 	<p><b>#368</b> Panorama™ Supra Pieces per layer: 6 Layers per pallet: 10 Sq. ft. per pallet: 103</p> 
<p><b>#267/#267T</b> Venetian® 6x6/6x9 Bundle Pieces per layer: 30 Layers per pallet: 10 Sq. ft. per pallet: 95</p> 	<p><b>#269/#269T</b> Venetian® 6x12 Pieces per layer: 20 Layers per pallet: 10 Sq. ft. per pallet: 96</p> 	<p><b>#270/#270T</b> Venetian® 12x12 Pieces per layer: 12 Layers per pallet: 10 Sq. ft. per pallet: 120</p> 	<p><b>#369</b> Venetian® Flag Pieces per layer: 5 Layers per pallet: 10 Sq. ft. per pallet: 80</p> 
<p><b>#293/#293T</b> Vintage Stone® 3-pc Pieces per layer: 48 Layers per pallet: 10 Sq. ft. per pallet: 116</p> 	<p><b>#217</b> Holland Stone - 60mm Pieces per layer: 48 Layers per pallet: 10 Sq. ft. per pallet: 103</p> 	<p><b>#200</b> CityScape ADA Pieces per layer: 48 Layers per pallet: 10 Sq. ft. per pallet: 103</p> 	<p><b>#213</b> CityStone™ 4x4 Pieces per layer: 96 Layers per pallet: 10 Sq. ft. per pallet: 103</p> 

## TYPICAL CROSS SECTION OF CONCRETE PAVER INSTALLATION

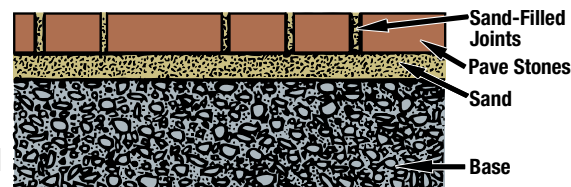

# PALLET OVERVIEW | by Wall

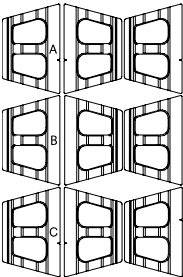
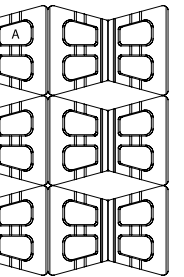
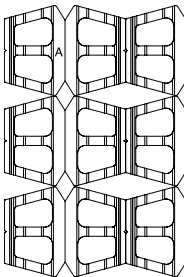
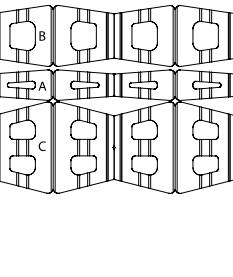
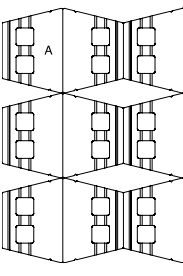
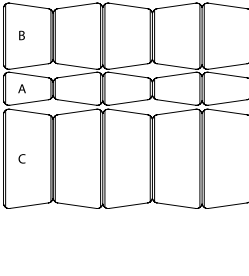
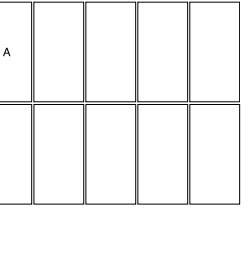
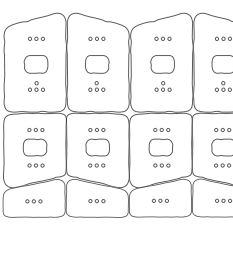
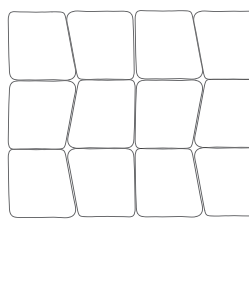
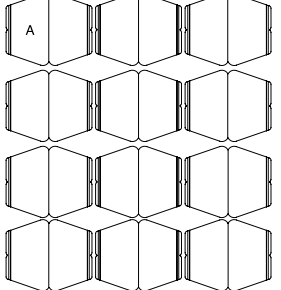
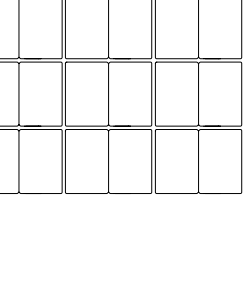
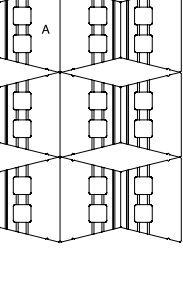
<p><b>#888</b> Regal Stone Pro® - Medley Pieces per layer: 9 Layers per pallet: 4</p> 	<p><b>#818</b> Regal Stone Pro® - RockFace Pieces per layer: 9 Layers per pallet: 4</p> 	<p><b>#826</b> Regal Stone Pro® - Tri-Plane Pieces per layer: 9 Layers per pallet: 4</p> 	<p><b>#876</b> Harington® 3-pc Pieces per layer: 12 Layers per pallet: 5</p> 
<p><b>#883</b> Harington® Large Pieces per layer: 9 Layers per pallet: 5</p> 	<p><b>#889N</b> Harington® Freestanding 3-pc Pieces per layer: 15 Layers per pallet: 4</p> 	<p><b>#519</b> Rumbled Wall™ Pieces per layer: 10 Layers per pallet: 7</p> 	<p><b>#110176 / #110176T</b> Stonegate® Pieces per layer: 12 Layers per pallet: 5</p> 
<p><b>#110177 / #110177T</b> Stonegate® Cap Pieces per layer: 12 Layers per pallet: 10</p> 	<p><b>#811</b> 12" Retaining Wall Pieces per layer: 24 Layers per pallet: 6</p> 	<p><b>#814</b> 12" Retaining Wall Cap Pieces per layer: 12 Layers per pallet: 10</p> 	<p><b>#870</b> Harington® Medley Pieces per layer: 9 Layers per pallet: 5</p> 

### Color Variations

As in all natural materials, color in paving stones and wall stones has inherent variations. Paver and wall color is affected by the variances in the raw materials, concrete mixture, moisture content, climactic conditions, and other variations. Therefore, the colors shown are approximate representations of paver and wall colors, but should not be expected to be an exact match of what will be delivered.

### The Nature of Efflorescence

Another cause of color variation in paving stones and wall stones may be the natural phenomenon called efflorescence. Efflorescence, a deposit of white salts consisting of mostly calcium carbonate, may appear as a white powder on the paver or wall surface and in no way affects the structural integrity. This phenomenon occurs in all concrete and although it cannot be completely prevented from occurring, efflorescence generally will weather off and disappear over time or can be removed with cleaners at the job site.

# PALLET OVERVIEW | by Corner & Cap

Let this six-piece series bring your next hardscape design to life with sophistication and style. Panorama Demi & Supra can also be installed as two stand-alone three-piece paving systems.



**#110894**  
6" RockFace Corner  
Pieces per layer: 10  
Layers per pallet: 4

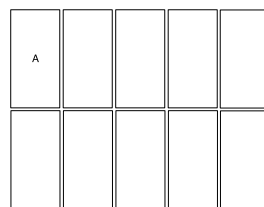

**#110865**  
8" Straight Corner  
Pieces per layer: 10  
Layers per pallet: 4



**#817**  
3" Trapezoid Cap  
Pieces per layer: 9  
Layers per pallet: 8

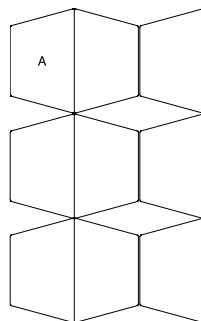

**#110819**  
3" Rectangle Cap  
Pieces per layer: 6  
Layers per pallet: 8

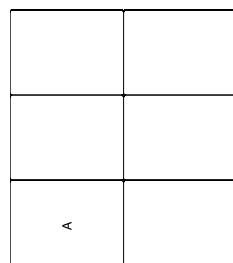

**#830**  
4" Trapezoid Cap  
Pieces per layer: 9  
Layers per pallet: 7

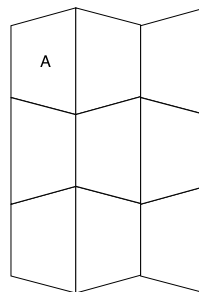

# COLOR MATRIX

This color matrix serves as a guide for color selection across product lines.

		Standard														Tumbled									
		Antique Red	Charcoal	Chicago Blend	Eddington Blend	Glacier Blend	Granite Blend	Hearthstone Blend	Merriam Blend	Oaks Blend	Ozark Blend	Pecan	Pewter	River Red	Sand Blend	Savannah	Terra Cotta	Trinity Blend	Winter Blend	Eddington Blend	Granite Blend	Hearthstone Blend	Merriam Blend	Ozark Blend	Winter Blend
<b>Prod. No.</b>	<b>PAVER COLLECTION</b>																								
363	CityStone Demi 60mm					•	•																		
364	CityStone Supra 60mm					•	•																		
367	Panorama Demi 60mm				•			•							•			•							
368	Panorama Supra 60mm				•			•							•			•							
267/267T	Venetian 2-pc 60mm						•		•		•								•		•		•	•	•
269/269T	Venetian 6x12 60mm						•		•		•								•		•		•	•	•
270/270T	Venetian 12x12 60mm						•		•		•								•		•		•	•	•
369	Venetian Flag 60mm														•										
293/293T	Vintage Stone 3-pc 60mm								•		•								•				•	•	•
217	Holland Stone 60mm	•	•																						
200	CityScape ADA Paver 60mm													•											
213	CityStone 4x4 60mm												•												
<b>Prod. No.</b>	<b>WALL COLLECTION</b>																								
888	Regal Stone Pro - Medley			•							•				•										
818	Regal Stone Pro - RockFace			•							•		•		•	•									
826	Regal Stone Pro - Tri-Plane											•				•									
876	Harington 3-pc			•					•		•				•										
870	Harington Medley			•					•		•				•										
883	Harington Large			•					•		•		•		•	•									
889N	Harington Freestanding 3-pc			•					•		•				•										
519	Rumbled Wall			•					•		•				•										
110176T	Stonegate Old World																			•	•	•			
110176	Stonegate - Contemporary				•			•	•																
811	12" Retaining Wall								•	•		•	•	•		•	•		•						
<b>Prod. No.</b>	<b>WALL CAPS &amp; CORNERS</b>																								
110894	6" RockFace Corner			•					•		•				•										
110865	8" Straight Corner			•							•		•		•	•									
110177T	Stonegate Cap																			•	•	•			
110177	Stonegate Cap - Contemporary				•			•	•																
817	3" Trapezoid Cap			•					•		•				•										
110819	3" Rectangle Cap			•					•		•				•	•									
830	4" Trapezoid Cap			•					•		•				•	•									
814	12" Retaining Wall Cap												•		•										
<b>Prod. No.</b>	<b>OUTDOOR LIVING</b>																								
496-RPT	Harington FSW Round Fire Pit Kit			•					•		•				•										
496-SPT	Rumbled Wall Square Fire Pit Kit			•					•		•				•										

# COLOR CHART

CODE	COLOR	COLOR DESCRIPTION	PAVER	WALL	COMPLEMENTARY COLOR
11	Antique Red	Blended Color: River Red & Charcoal	- Holland	No	- Charcoal
03	Charcoal	Solid Color: Dark Gray	- Holland	No	- Antique Red - Eddington Blend - Chicago Blend - Granite Blend - Ozark Blend - Winter Blend - Pewter
46	Chicago Blend	Blended Color: Pewter & Charcoal	No	- Regal Stone Pro - Medley - Regal Stone Pro - RockFace - Rumbled Wall - Harington Series	- Charcoal - Eddington Blend - Glacier Blend - Granite Blend - Pewter
29	Eddington Blend	Blended Color: Tan, Charcoal & Pewter	- Panorama	- Stonegate	- Charcoal - Pewter - Chicago Blend - Granite Blend - Ozark Blend - Sand Blend
78.GLB	Glacier Blend	Blended Color: White & Pewter	- CityStone Demi & Supra	No	- Charcoal - Chicago Blend - Granite Blend - Pewter - Sand Blend
57	Granite Blend	Blended Color: White, Pewter, & Charcoal	- CityStone Demi & Supra - Venetian	- Stonegate	- Chicago Blend - Glacier Blend - Pewter - Charcoal
78.HTH	Hearthstone Blend	Blended Color: Dark Brown, Tan & Cream	- Panorama	- Stonegate	- Merriam Blend - Trinity Blend
78.SBNP	Merriam Blend	Blended Color: Tan & Cream	- Venetian - Vintage	- Harington Series - Rumbled Wall	- Hearthstone Blend - Sand Blend - Trinity Blend
28	Ozark Blend	Blended Color: Charcoal & Tan	- Venetian - Vintage	- Harington Series - Regal Stone Pro - Medley - Regal Stone Pro - Rockface - Rumbled Wall	- Charcoal - Eddington Blend - Sand Blend - Winter Blend
00	Pewter	Solid Color: Natural Concrete Color	No	- Harington Large - Regal Stone Pro - Rockface - Regal Stone Pro - Tri-Plane	- Chicago Blend - Glacier Blend - Granite Blend - Sand Blend - Winter Blend
14	Sand Blend	Blended Color: Tan, Gray & Cream	- Panorama - Venetian Flag	- Harington Series - Regal Stone Pro - Medley - Regal Stone Pro - RockFace - Rumbled Wall	- Eddington Blend - Ozark Blend - Merriam Blend - Pewter
27	Savannah	Solid Color: Medium Earth Tone Brown	No	- Harington Large - Regal Stone Pro - Tri-Plane - Regal Stone Pro - Rockface	- Winter Blend
95	Trinity Blend	Blended Color: Cream, Rusty Tan & Dark Brown	- Panorama	No	- Hearthstone Blend - Merriam Blend
87	Winter Blend	Blended Color: Charcoal, Pewter, Sandstone, Dark Reddish Brown	- Venetian - Vintage Stone	No	- Charcoal - Ozark Blend - Pewter - Savannah



## Product Warranty

LIMITED WARRANTY for the Contract Professional, Developer, or other Commercial Purchaser Keystone Hardscapes, having its headquarters located at Five Concourse Parkway, Atlanta, GA 30328, warrants its products at the time of delivery will meet or exceed the applicable ASTM standards on compressive strength and absorption if installed in accordance with applicable ICPI ([www.icpi.org](http://www.icpi.org)) or NCMA ([www.ncma.org](http://www.ncma.org)) standards. This warranty does not cover standard manufacturing variations, color variations/matching or efflorescence. Keystone Hardscapes is not responsible for installation of the product or defective conditions caused by installation, abuse, impact, abrasion or alteration of the product, earth-shifts, excessive or unforeseen site conditions, acts of God or application of de-icing salt or other chemicals to the product. Liability under this warranty, if the product is found to be defective, is limited to the replacement of the defective product, or at Keystone Hardscapes' option, the refund of the purchase price of the defective product. Keystone Hardscapes does not guarantee that the shape or color will be available in the future and will provide an alternate shape or color from its current product line as determined by Keystone Hardscapes at the time of an accepted warranty claim. This warranty is valid for the lifetime of the product. This warranty is transferable. In the event of a claim under this warranty, notice must be given to Keystone Hardscapes, together with original proof of purchase, at its headquarters by sending a letter to: Keystone Hardscapes a/s Warranties, Five Concourse Parkway, Atlanta, GA 30328. THIS WARRANTY IS ISSUED AND ACCEPTED IN LIEU OF ANY AND ALL OTHER EXPRESS OR IMPLIED WARRANTIES OF ANY KIND OR NATURE AND EXPRESSLY EXCLUDES LIABILITY FOR LABOR, FREIGHT AND OTHER COSTS ASSOCIATED WITH REMOVAL AND REPLACEMENT OF THE DEFECTIVE PRODUCT AND FOR INDIRECT AND CONSEQUENTIAL DAMAGES.

Due to variations in the printing and photographic processes, actual appearance and color of our products may differ from the appearance reflected in this website or in any of our brochures or other product literature and appearance and color may differ from one brochure or other product literature to the next. Please be advised that this warranty does not cover those appearance and color variations.

Once installed, our products are deemed accepted in terms of surface texture, shape, size, split face geometry, color, color blending and all other aesthetic features.



FOLLOW US     

## Where imagination and possibilities meet.

Keystone Hardscapes pavers and retaining walls are the building blocks that turn your ideas into realities. Dreaming of extending your living space with a backyard gathering area to entertain family and friends? From distinctive driveways to luxurious outdoor living designs, Keystone Hardscapes can help bring your vision to life.

Keystone Hardscapes is built on a commitment to beauty, design versatility and function.

Since the 1980s, our products have been installed in thousands of residential and commercial properties. Our innovative pavers, walls and outdoor living elements continue to be favorites of homeowners, contractors, designers and developers.

**Locally made products, nationally trusted brand.**

Manufactured at:

KANSAS CITY, MO  
601 N.E. Pavestone Drive  
Lee's Summit, MO 64064  
Phone: 816-524-9900

QUIKRETE and its subsidiaries (collectively QUIKRETE) reserve the right to improve its products and make changes to its specification and design without notice. The information contained herein has been compiled by QUIKRETE and to the best of its knowledge, accurately represents Keystone Hardscapes products and how it may be used in the applications which are illustrated. Site conditions, including load pressures acting on the wall, soil types and drainage conditions, may vary. Final determination of the suitability of the product for the use contemplated and the manner of product use are the sole responsibility of the user. Good construction practices and local building codes require the use of an engineered design when constructing retaining walls or freestanding walls in many conditions. Structural design and analysis should be provided by a qualified engineer.

©2023 The QUIKRETE Companies - Patents Pending. • KHS - 02/2023